



***Audio Monitor***

**3300**

**INSTRUCTION MANUAL**

**FOR**

**AUDIO MONITOR**

**MODEL 3300**

Serial # \_\_\_\_\_

Date \_\_\_\_\_

**A-M Systems**  
**PO Box 850**  
**Carlsborg, WA 98324**  
**U.S.A.**

**360-683-8300 ♦ 800-426-1306**

**FAX: 360-683-3525**

**<http://www.a-msystems.com>**

**Version 5.0**  
**March 2020**

# Contents

<b>General Description</b> .....	1
Instrument Features .....	1
Controls and Connectors.....	2
<b>Operating Instructions</b> .....	3
<b>Theory of Operation</b> .....	4
<b>Specifications</b> .....	5
<b>Warranty and Service</b> .....	7

***Each Audio Monitor is  
delivered complete with:***

***Rack Mount Hardware  
International Remote Power Supply I***

## **NOTE**

*This instrument is not intended for clinical measurements using human subjects. A-M Systems does not assume responsibility for injury or damage due to the misuse of this instrument.*

# General Description

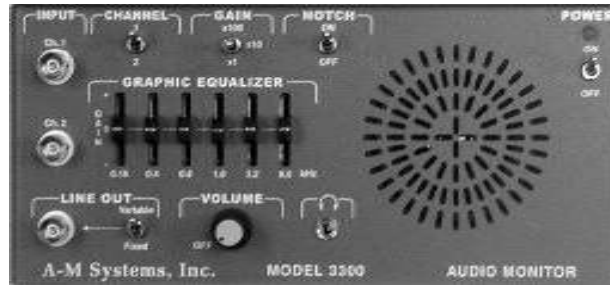

## Instrument Features

The *Model 3300 Audio Monitor* is a high quality audio amplifier designed to transform electrophysiological signals into sounds. This amplifier features a built-in 6-band audio equalizer that enables the user to tailor the audio performance to their personal satisfaction, a high-fidelity quality speaker, a dedicated notch filter designed to minimize noise interference generated by power lines, a headphone jack, and an BNC line out jack that enables the the *Model 3300* to be used as another signal amplifier prior to subsequent processing by other instruments.

The instrument can be placed on a lab bench with its built-in metal stand, or it can be mounted in any industry standard equipment rack (with included rack-mounting hardware). In addition, the instrument is shipped with it's own desktop power supply.

It can be used in a number of research or teaching applications requiring the audio reproduction of electrophysiological signals, such as such as nerve, muscle (EMG), EEG, EKG, and ERG recordings.

**The instrument is not intended for clinical measurements using humans.**

Two input signals can be passed to the *Model 3300*. A toggle switch selects which of the two signals will be amplified and processed by the 6-band equalizer. The Equalizer is a tunable filter that can increase or decrease the gain of particular frequency ranges, resulting in a pleasing sound quality produced at the speaker. The use of a set of headphones (by utilizing the mini-headphone jack) will disable the internal audio speaker. The volume control acts as a variable gain amplifier, and adjusts the volume of the speaker output. The processed signal can be passed to an oscilloscope or other instruments via the Signal Out BNC jack.

## Controls and Connectors

**INPUT:** Signals to be processed are connected to the Audio Monitor at these two BNC jacks (**Ch. 1** and **Ch. 2**).



input signals

**CHANNEL:** This toggle switch determines which of the two will be processed.

**GAIN:** This three position switch controls the level of signal gain. The switch allows the user to select from **X1**, **X10**, or **X100** gain.



**NOTCH FILTER:** In the ON position, this filter will attenuate line noise (Either 50 or 60 Hz, depending on the country of use).



**GRAPHIC EQUALIZER:** These 6 slide potentiometers adjust the gain of a narrow range of frequencies. Each slide potentiometer can boost/increase (+) or attenuate/decrease (-) the gain around the center frequency indicated (160Hz, 400Hz, 800Hz, 1.6kHz, 3.2kHz, and 8.0kHz) by 12dB.

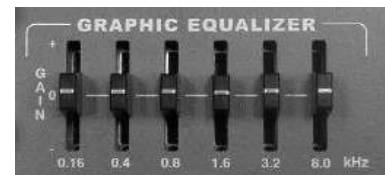

**LINE OUT:** This BNC connector provides the output signal from the amplifier channel. The toggle switch determines if this signal is *FIXED* in gain relative to the input signal (at the level determined by the **GAIN** toggle switch or includes the *VARIABLE* amplification provided by the **GRAPHIC EQUALIZER AND VOLUME** control.



**VOLUME:** This potentiometer adjusts the output volume of the speaker, and the variable amplification to the processed signal. *Warning: It is recommended to turn this knob to the off position before attaching an input signal to the Audio Monitor, in order to prevent damage to the speaker, and any nearby eardrums.*



**HEADPHONES JACK:** Insertion of a mini-headphones plug into this jack will disable the internal speaker, and power the user supplied headphones.

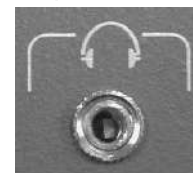

# Operating Instructions

## Typical Set-Up Procedure

*Turn the **VOLUME** control to the off position prior to connecting an input signal to either of the two input channels in order to prevent damage to the internal speaker or any nearby eardrums.*

Using the Channel Switch, select the desired input signal channel to be amplified. Determine the gain setting. Start with the lowest **GAIN** setting possible, and slowly increase the **VOLUME** control until a desired audio level is obtained. If you reach the maximum setting on the **VOLUME** control and the signal is still too quiet, return the **VOLUME** control to the off position and increase the **GAIN** to the next greater level.

If you would like to minimize power line generated noise, switch the **NOTCH** filter to *On*.

Adjust the **GRAPHIC EQUALIZER** slide knobs to increase or decrease the gain of certain frequency ranges in order to produce a more pleasing audio sound.

# Theory of Operation

One of two inputs may be selected using the **CHANNEL** switch. The selected input is then amplified according to the setting of the **GAIN** switch. After amplification, the signal can be filtered at the frequency of the power line by use of the **NOTCH** filter.

Particular narrow ranges of frequencies of the processed signal can then be boosted or attenuated using the **GRAPHIC EQUALIZER**. Maximum boost or attenuation is +/- 12dB, centered on the frequency indicated under each slide knob.

The output of the graphic equalizer feeds directly into the **VOLUME** control and **LINE OUTPUT**. Setting the **LINE OUT** Switch to *Variable* will produce the processed signal with the additional variable gain provided by the **VOLUME** control at the BNC jack. Setting the **LINE OUT** Switch to *Fixed* will provide the processed signal at the gain indicated by the **GAIN** switch (taken prior to the **GRAPHIC EQUALIZER**) at the BNC output jack.

The signal is then amplified using a power amplifier circuit in order to provide enough current to drive either the internal speaker or an external user-supplied set of headphones. Inserting a mini-headphones plug into the headphones jack will disable the internal speaker.

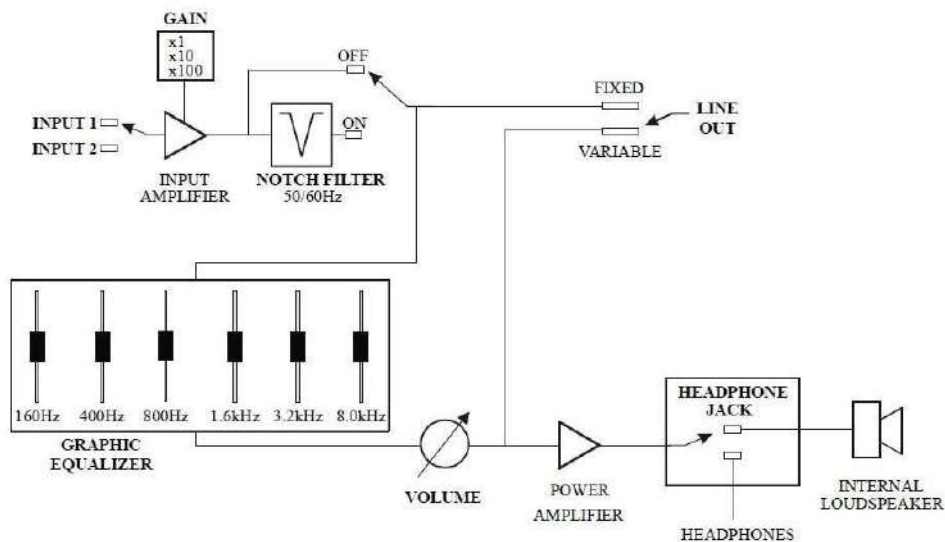

Figure 1. Main circuit block diagram

# Specifications

## Amplifier

**Gain:** 1V/V, 10V/V, 100V/V (+40dB)

**Sensitivity:** 0.01V p-p

**Input resistance:** 20M $\Omega$

### Maximum input before LINE OUT clips:

GAIN: x1 10.0V

GAIN: x10 1.0V

GAIN: x100 0.1V

### Maximum input before SPEAKER clips (*with volume control fully clockwise*):

GAIN: x1 1.0V

GAIN: x10 0.1V

GAIN: x100 0.01V

### Noise (*At Fixed Line Out*)

470 $\Omega$  source resistance (not shorted input)

22Hz-22kHz: 14 $\mu$ V p-p (57dB signal to noise)

1kHz spot frequency: 3 $\mu$ V p-p (70dB signal to noise)

2,200pF source capacitance to emulate a crystal/ceramic transducer source

Without NOTCH Filter (22Hz-22kHz): 220 $\mu$ V p-p (33dB signal to noise)

With NOTCH Filter (22Hz-22kHz): 28 $\mu$ V p-p (51dB signal to noise)

1kHz spot frequency: 1 $\mu$ V p-p (80dB signal to noise)

### Notch Filter

Gain: Unity (0dB)

Notch Frequency: 60Hz (50Hz in specific countries) Notch Depth: -

29dB

### Graphic Equalizer

Gain: Unity (0dB)

Boost/Cut Frequencies (Hz): 160, 400, 800, 1600, 3200, 8000 Nominal

Boost & Cut: +/- 10dB (within 1dB)

### Power Amplifier

Power output: 2.7W continuous (rms) sine wave into 4 $\Omega$

5.4W continuous (peak) sine wave into 4 $\Omega$



Distortion (THD+N):	<0.3%, 80Hz - 16kHz (at rated power)
Frequency response:	100Hz - 26kHz, -3dB points (470µf output capacitor)
Amplification	x10

## Physical Dimensions

Width	8.5 inches (22 cm)
Height	4.25 inches (11 cm)
Depth	2.5 inches (7 cm)
Weight	4 lbs.

# Warranty and Service

## LIMITED WARRANTY

### **What does this warranty cover?**

A-M Systems, LLC (hereinafter, “A-M Systems”) warrants to the Purchaser that the Instruments manufactured by A-M Systems (hereinafter the “hardware”), and sold after January 1, 2020, is free from defects in workmanship or material under normal use and service for the lifetime of the hardware. Headstages manufactured by A-M Systems and sold after January 1, 2020, will be repaired under warranty only once per year. This warranty commences on the date of delivery of the hardware to the Purchaser. “Lifetime” is defined as the time all components in the instrument can still be purchased from mainstream, common, electronic component distributors such as Digi-Key Electronics, Newark, or Mouser Electronics.

For hardware sold prior to January 1, 2020, the warranty in effect at time of purchase applies, with the maximum warranty period of three (3) years for new purchases, and one (1) year for those that have been repaired by A-M Systems. For headstages manufactured by A-M Systems and sold prior to January 1, 2020, the maximum warranty period is one (1) year.

### **What are the obligations of A-M Systems under this warranty?**

During the warranty period, A-M Systems agrees to repair or replace, at its sole option, without charge to the Purchaser, any defective component part of the hardware. To obtain warranty service, the Purchaser must return the hardware to A-M Systems or an authorized A-M Systems distributor in an adequate shipping container. Any postage, shipping and insurance charges incurred in shipping the hardware to A-M Systems must be prepaid by the Purchaser, and all risk for the hardware shall remain with Purchaser until A-M Systems takes receipt of the hardware. Upon receipt, A-M Systems will promptly repair or replace the defective unit and then return the hardware (or its replacement) to the Purchaser with postage, shipping, and insurance prepaid by the Purchaser. A-M Systems may use reconditioned or like-new parts or units at its sole option, when repairing any hardware. Repaired products shall carry the same amount of outstanding warranty as from original purchase. Any claim under the warranty must include a dated proof of purchase of the hardware covered by this warranty. In any event, A-M Systems liability for defective hardware is limited to repairing or replacing the hardware.

### **What is not covered by this warranty?**

This warranty is contingent upon proper use and maintenance of the hardware by the Purchaser and does not cover batteries. Neglect, misuse whether intentional or otherwise, tampering with or altering the hardware, damage caused

## LIMITED WARRANTY, cont

by accident, damage caused by unusual physical, electrical, chemical, or electromechanical stress, damage caused by failure of electrical power, or damage caused during transportation are not covered by this warranty. Further, no guarantee is made regarding software compatibility with future updated operating systems. Products may not be returned to A-M Systems for service, whether under warranty or otherwise, which are contaminated by infectious agents, radioactive compounds or other materials constituting a health hazard to employees of A-M Systems

### **What are the limits of liability for A-M Systems under this warranty?**

A-M Systems shall not be liable for loss of data, lost profits or savings, or any special, incidental, consequential, indirect or other similar damages, whether arising from breach of contract, negligence, or other legal action, even if the company or its agent has been advised of the possibility of such damages, or for any claim brought against you by another party.

THIS EQUIPMENT IS NOT INTENDED FOR CLINICAL MEASUREMENTS USING HUMAN SUBJECTS.

A-M SYSTEMS DOES NOT ASSUME RESPONSIBILITY FOR INJURY OR DAMAGE DUE TO MISUSE OF  
THIS EQUIPMENT.

Jurisdictions vary with regard to the enforceability of provisions excluding or limiting liability for incidental or consequential damages. Check the provision of your local jurisdiction to find out whether the above exclusion applies to you.

This warranty allocates risks of product failure between the Purchaser and A-M Systems. A-M Systems hardware pricing reflects this allocation of risk and the limitations of liability contained in this warranty. The agents, employees, distributors, and dealers of A-M Systems are not authorized to make modifications to this warranty, or additional warranties binding on the company. Accordingly, additional statements such as dealer advertising or presentations, whether oral or written, do not constitute warranties by A-M Systems and should not be relied upon. This warranty gives you specific legal rights. You may also have other rights which vary from one jurisdiction to another.

THE WARRANTY AND REMEDY PROVIDED ABOVE IS IN LIEU OF ALL OTHER WARRANTIES AND REMEDIES, WHETHER EXPRESS OR IMPLIED. A-M SYSTEMS DISCLAIMS THE WARRANTIES OF MERCHANTABILITY AND FITNESS FOR A PARTICULAR USE, WITHOUT LIMITATION.

**Revision History**

<b>Rev</b>	<b>Date</b>	<b>Description</b>
1	6/30/06	Initial Document Control release
2	4/28/10	DCR 201200 Warranty and company information
3	9/20/16	DCR 202474. Review Manual for accuracy.
4	1/18/19	DCR 202615. Update content, add content rev control.
5	3/19/20	DCR 203316. Update Warranty