

## OptiScan III™ Motorised Stage Systems

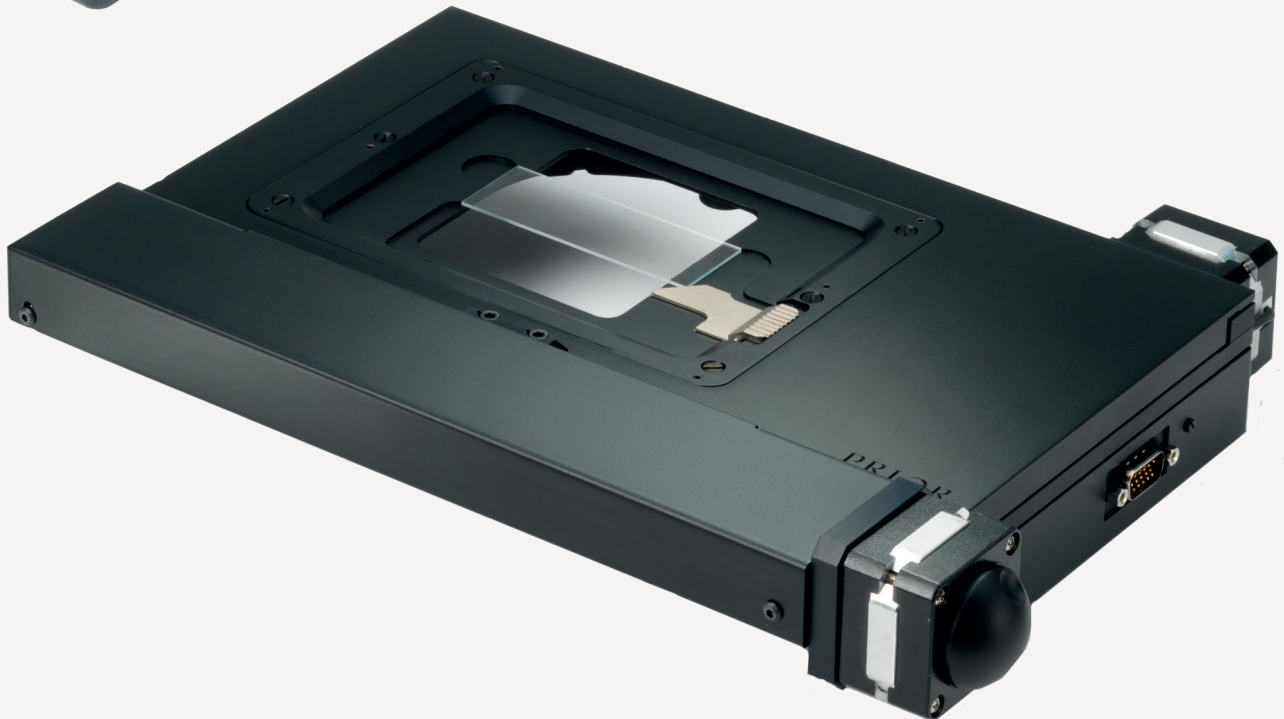

## OptiScan III™

Motorised Stage Systems

The OptiScan™ III is the latest in a long line of high quality, precise automated systems designed and manufactured by Prior Scientific. Routine microscopy applications can be performed with much greater accuracy and speed without sacrificing either affordability or reliability. The combination of the OptiScan™ III controller, motorised stages and focussing mechanisms allows great flexibility and creates a powerful system tailored to your specific needs.

### OptiScan™ III Controller

The controller is at the heart of the system and is compact, yet powerful and versatile. It is compatible with the majority of popular image analysis software, allowing seamless integration between software and hardware. The controller is supplied with a software development tool-kit that includes comprehensive DLL, a VB demo program and a full complement of ASCII commands. The software developer can utilise either the USB or the RS232 serial port for software communications. The OptiScan™ III Controller can be used to control both motorised stages and focussing mechanisms. The 'plug & play' facility provides automatic configuration of system components making system set up very easy. Onboard flash memory enables simple firmware upgrades from your own computer.



### Motorised Stage Systems

OptiScan™ stages are ideally suited to a wide range of imaging applications. A wide range is available to fit most inverted and upright microscopes, and are compatible with the full range of Prior specimen holders; so examination of glass slides, multiwell plates, Petri dishes and metallurgical specimens is possible. Thanks to a unique S-curve acceleration algorithm, movement and positioning is smooth and without vibration.

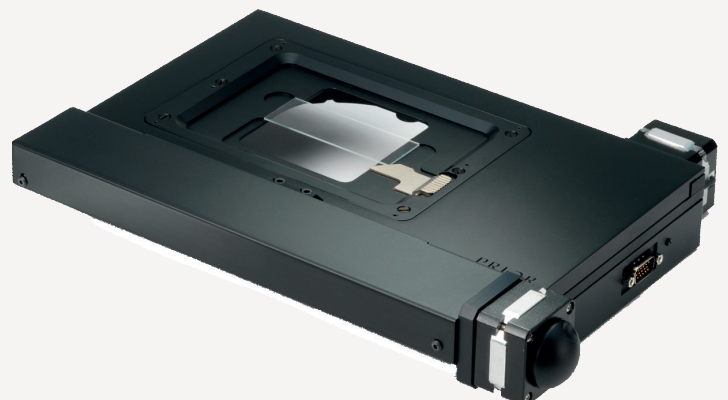

## OptiScan III™

Motorised Stage Systems



### Focus drive

By adding the PS3H122 Focus Drive into your microscope, it is possible to finely control not only the motorised stage but also the focussing of the microscope itself, via either a joystick or from a computer. Step sizes as small as 0.1µm give extra resolution for precise focussing and repeatability. If larger movements are required, the motor can be driven at speeds of up to 16 revs/s.



### Ergonomic joystick

The joysticks offer precise and ergonomic control of the stage, and, if required, the focus drive, allowing the user to use the joystick to focus the microscope as well, offering total and precise control of the X, Y and Z axes.

**Prior Scientific manufactures a wide range of products designed for a huge range of microscopy applications; from automated systems to illuminators, sample holders, filter wheels and robotic slide loaders.**

### Specifications

Power	Universal external power supply; Input 100-240V, 50/60Hz max 1.6A
Communications Protocol	USB, RS232 at 9600, 19200, 38400 or 115200 baud, 8 bit word, 1 stop bit, no parity, no handshake
Axes	X Y and Z
Dimensions	294 mm x 193 mm x 60 mm
Weight	2.2 kg

**OptiScan III™**  
Motorised Stage Systems

**OptiScan™ III Flexibility**

Many different applications require or benefit from microscope automation. Designed with this in mind, OptiScan™ III is flexible and its components can be configured to precisely match your requirements and budget. Furthermore, the modularity of the system means that it is simple to upgrade your system if your requirements change. Please contact a Prior representative, email us or visit our website to learn more.

**2 Axis System**

Used solely for control of the motorised stage



**3 Axis System**

Used for control of the motorised stage and of focussing



**Worldwide distribution**

**Prior Scientific Ltd**  
Cambridge, UK  
T. +44 (0) 1223 881 711  
E. [uksales@prior.com](mailto:uksales@prior.com)

**Prior Scientific Inc**  
Rockland, MA USA  
T. +1 781-878-8442  
E. [info@prior.com](mailto:info@prior.com)

**Prior Scientific GmbH**  
Jena, Germany  
T. +49 (0) 3641 675 650  
E. [jena@prior.com](mailto:jena@prior.com)

**Prior Scientific KK**  
Tokyo, Japan  
T. +81-3-5652-8831  
E. [info-japan@prior.com](mailto:info-japan@prior.com)



## ES111 Stage

Motorised Stage for use with the OptiScan® system

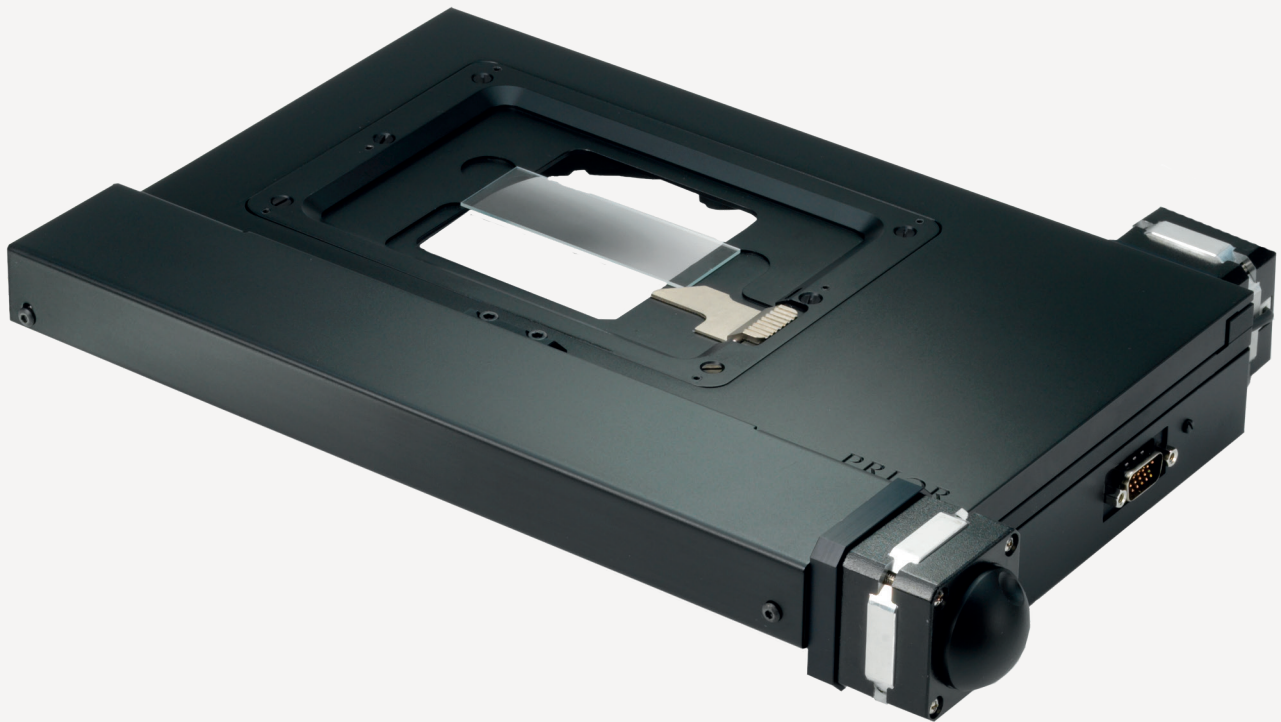

Economical yet precise, the ES111 motorised stage is designed to integrate with the OptiScan control system from Prior Scientific and fits with upright microscopes. The ES111 offers excellent control over the XY axes for a reduced outlay compared with other motorised stages on the market; ideal for the user who does not require a sub micrometre repeatability but nevertheless needs a reliable and accurate stage for routine and repetitive imaging applications.

- Step size (resolution) of 1  $\mu\text{m}$
- Repeatability of  $\pm 5 \mu\text{m}$
- Travel range 125 x 75 mm.
- Compatible with the full range of Prior specimen holders, including standard slide holders, multi-well plate holders, Petri dish holders and metallurgical specimen holders
- The unique S curve acceleration algorithm allows fast, smooth positioning without vibration, reducing disruption to samples.
- Anti-backlash precision lead screws
- Adjustable XY limit switches

## ES111Stage

Motorised Stage for the OptiScan System

### Dimensions

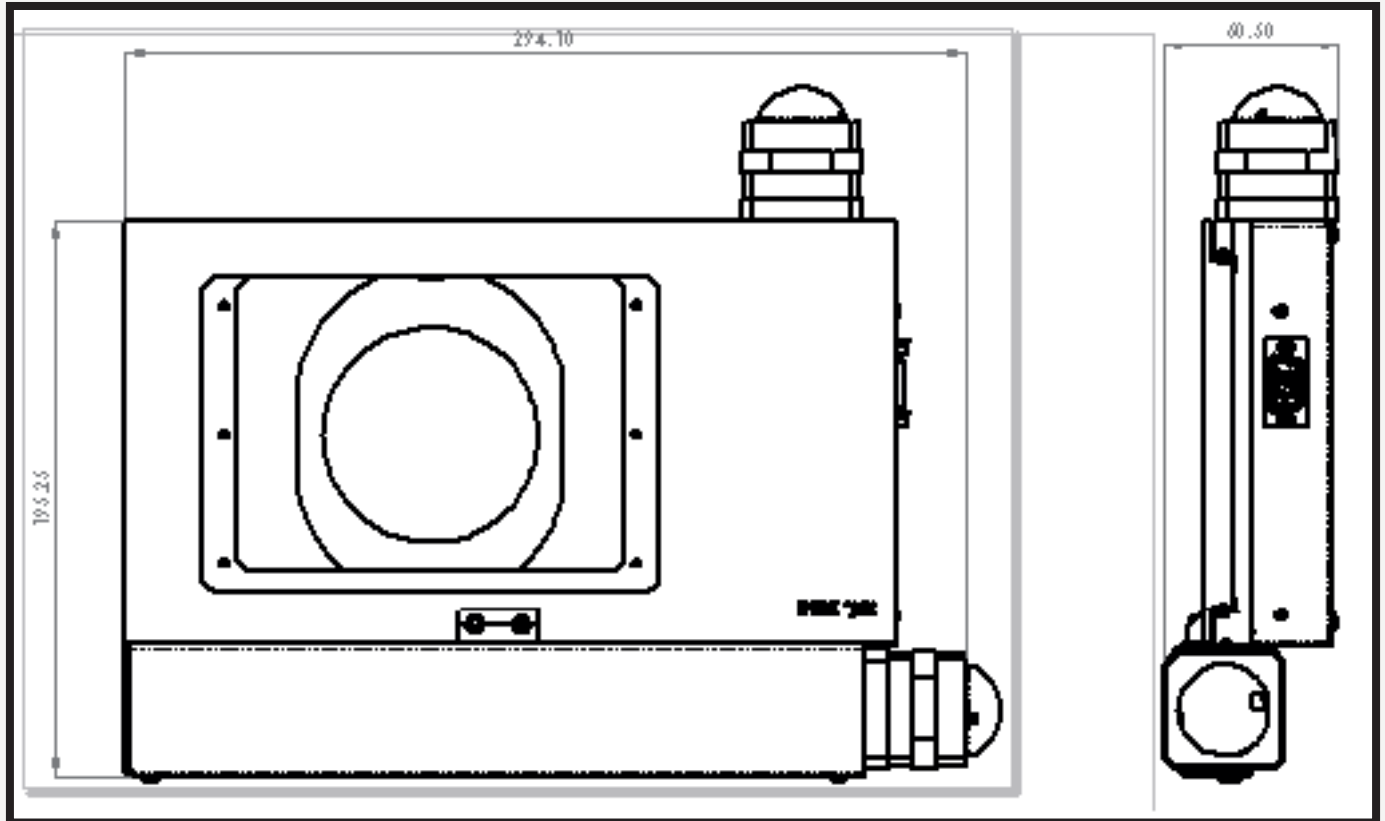

### Specifications\*

Feature	Specification
Travel Range:	Upright - 125 x 75 mm
Repeatability:	± 5 µm
Step size (Resolution):	1 µm
Linear Slides:	3 mm ball bearings
Drive mechanism:	Anti-backlash precision lead screw
Limit Switches:	X and Y standard, adjustable.

\* All specifications are based on the Prior method of testing and are only valid with a Prior controller

### Worldwide distribution

**Prior Scientific Ltd**  
Cambridge, UK  
T. +44 (0) 1223 881 711  
E. [uksales@prior.com](mailto:uksales@prior.com)

**Prior Scientific Inc**  
Rockland, MA USA  
T. +1 781-878-8442  
E. [info@prior.com](mailto:info@prior.com)

**Prior Scientific GmbH**  
Jena, Germany  
T. +49 (0) 3641 675 650  
E. [jena@prior.com](mailto:jena@prior.com)

**Prior Scientific KK**  
Tokyo, Japan  
T. +81-3-5652-8831  
E. [info-japan@prior.com](mailto:info-japan@prior.com)

## ES107 Stage

Motorised Stage for use with the OptiScan® system

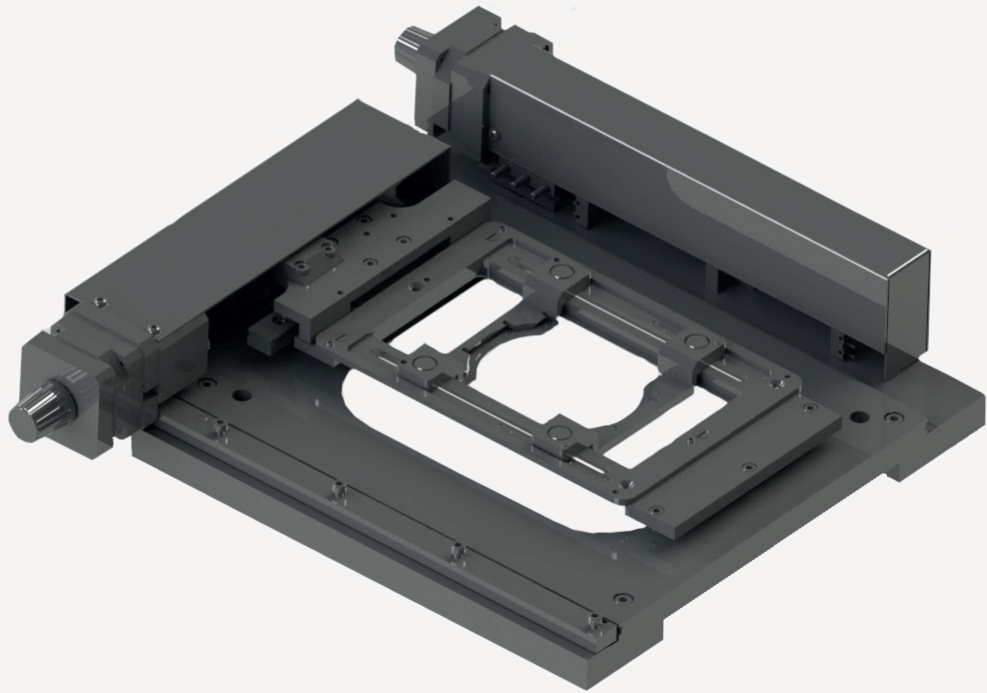

Economical yet precise, the ES107 motorised stage is designed to integrate with the OptiScan control system from Prior Scientific and fits with inverted microscopes. The ES107 offers excellent control over the XY axes for a reduced outlay compared with other motorised stages on the market; ideal for the user who does not require sub micrometre repeatability but nevertheless needs a reliable and accurate stage for routine and repetitive imaging applications.

- Step size (resolution) of 1  $\mu\text{m}$
- Repeatability of  $\pm 5 \mu\text{m}$
- Travel range 115 x 77 mm
- Compatible with the full range of Prior specimen holders, including standard slide holders, multi-well plate holders, Petri dish holders and metallurgical specimen holders
- The unique S curve acceleration algorithm allows fast, smooth positioning without vibration, reducing disruption to samples.
- Anti-backlash precision lead screws
- Semi adjustable XY limit switches

## ES107 Stage

Motorised Stage for the OptiScan System

### Dimensions

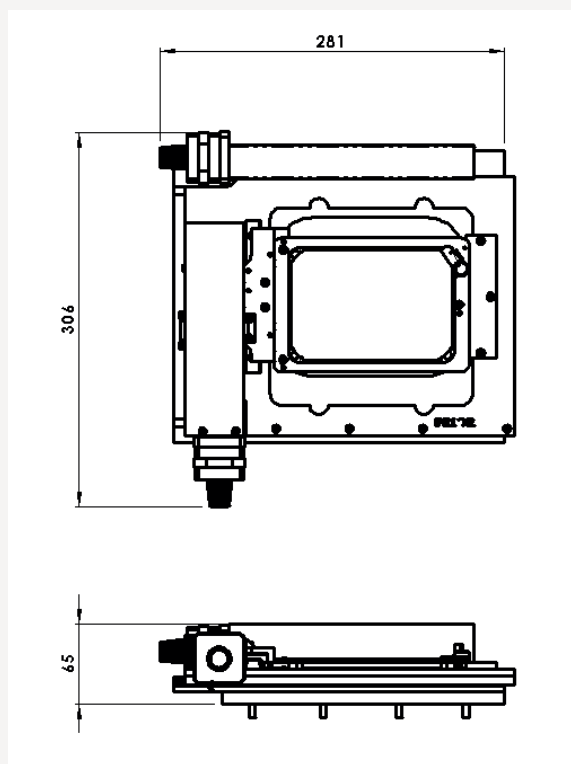

### Specifications\*

Feature	Specification
Travel Range:	115 x 77 mm
Repeatability:	± 5 µm
Step size (Resolution):	1 µm
Linear Slides:	3 mm ball bearings
Drive mechanism:	Anti-backlash precision lead screw
Limit Switches:	X and Y standard, semi adjustable.

\*Specifications obtained using the Prior method of testing and only valid when used with a Prior controller.

### Worldwide distribution

**Prior Scientific Ltd**  
Cambridge, UK  
T. +44 (0) 1223 881 711  
E. [uksales@prior.com](mailto:uksales@prior.com)

**Prior Scientific Inc**  
Rockland, MA USA  
T. +1 781-878-8442  
E. [info@prior.com](mailto:info@prior.com)

**Prior Scientific GmbH**  
Jena, Germany  
T. +49 (0) 3641 675 650  
E. [jena@prior.com](mailto:jena@prior.com)

**Prior Scientific KK**  
Tokyo, Japan  
T. +81-3-5652-8831  
E. [info-japan@prior.com](mailto:info-japan@prior.com)