

**OLYMPUS**<sup>®</sup>

Your Vision, Our Future

Fixed Stage Upright Microscope

**BX51WI / BX61WI**

**UIS2**  
World-leading optics

For Physiological Experiments



# A dual commitment: Preventing vibration and protecting living cell specimens

One design theme was central to the development of the fixed stage microscopes from Olympus — achieve an even higher standard of stability and reliability in electro-physiological applications. The result is a wide range of advanced features to avoid and prevent vibration. These innovations include the introduction of an observation method along with detailed analysis of operability and further refinements in image clarity. These improvements work together to make patch clamp operations smoother and more efficient than ever before.

Combined with the traditional excellence of UIS2 optics, the Olympus fixed stage microscopes provide high levels of quality in both performance and ease of use.



BX51WI with Luigs & Neumann Accessories.\*

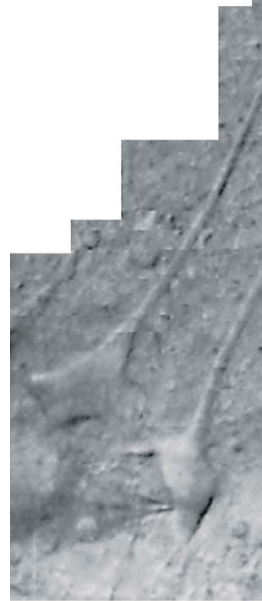

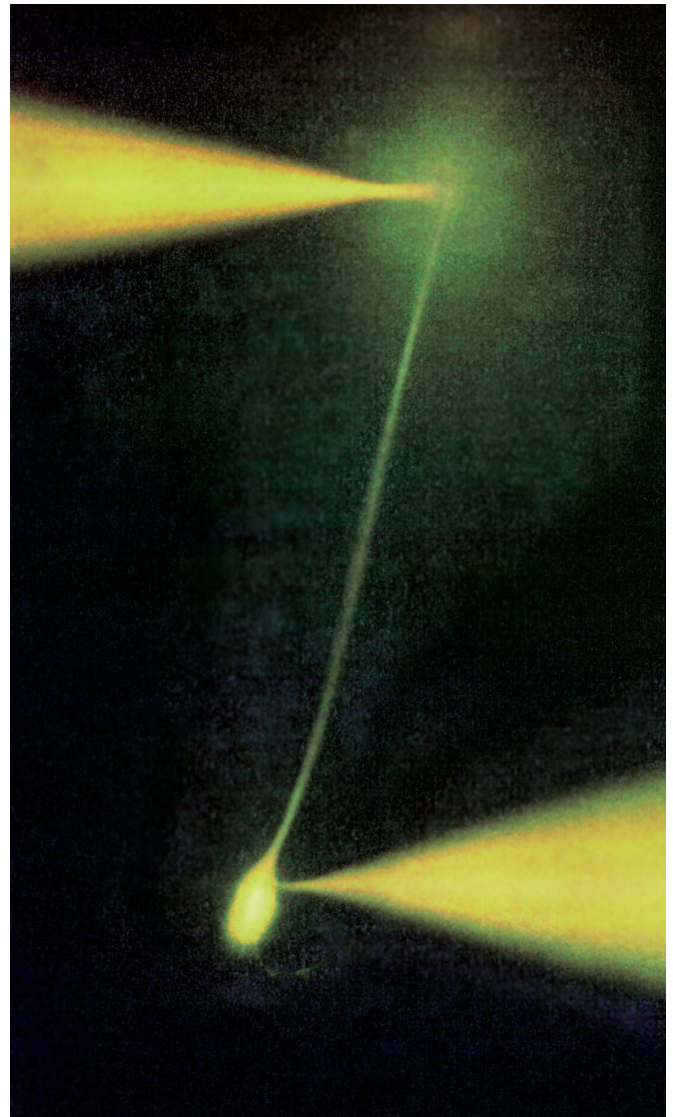
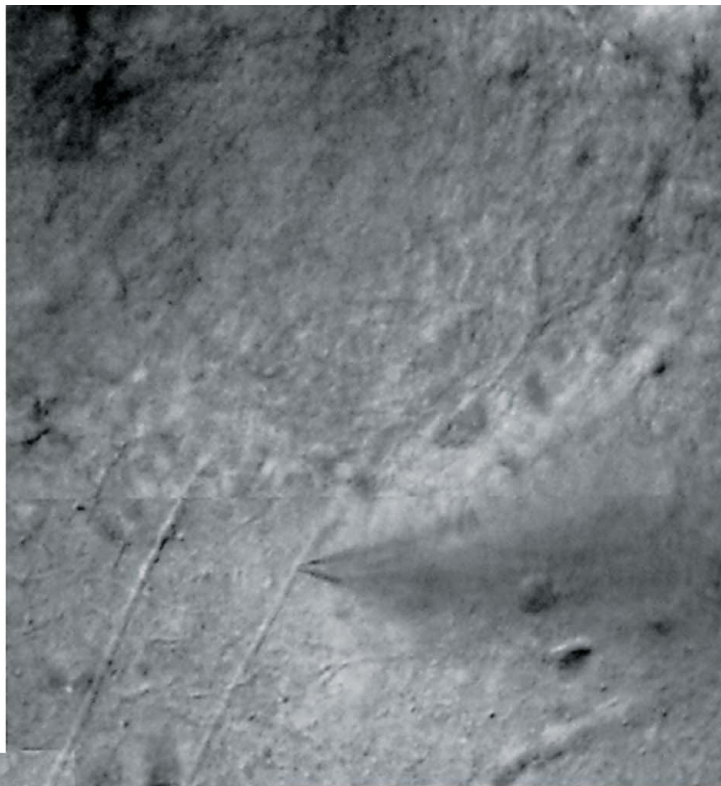

An intermediate magnification changer is used to change magnification without changing objectives

Front operation and reduced vibration for improved operability and stability

High NA objective offering excellent performance in IR-DIC observation, membrane potential imaging and fluorescence observation

Raising the objective and lowering the stage of the microscope enables easier experimentation on small animals

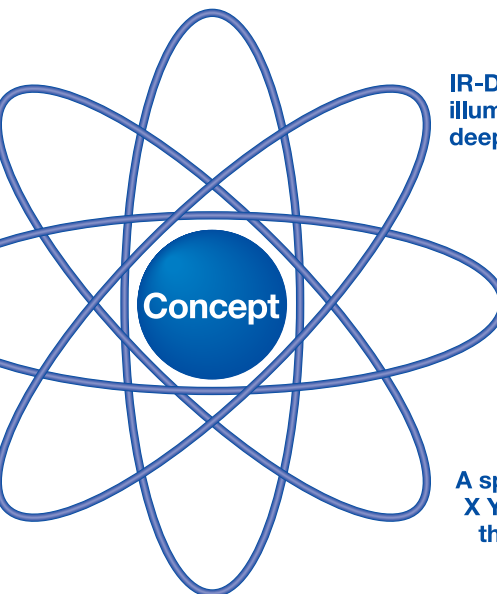

IR-DIC and IR oblique illumination condenser for deep-section observation

Full-system physiological confocal microscope, BX61WI with Z-axis motor is LSM ready

A special bridge stage and X Y mover are available for the microscope frame

Fluorescence macro objectives for membrane potential observation

\*The unit from third-party suppliers is included in the above system.

# Interchanging low and high magnifications without changing objectives

## Vibration-free design

A major concern for researchers conducting electro-physiology experiments is the vibration which occurs when switching objectives and the resulting interference this can cause to the specimens and adjacent equipment.

To solve this problem, Olympus has introduced the provision of an intermediate magnification changer in combination with the High NA long working distance 20X objective that allows the user to switch between low and high magnifications without the need to switch objectives.



7× Intermediate magnification 0.35 x

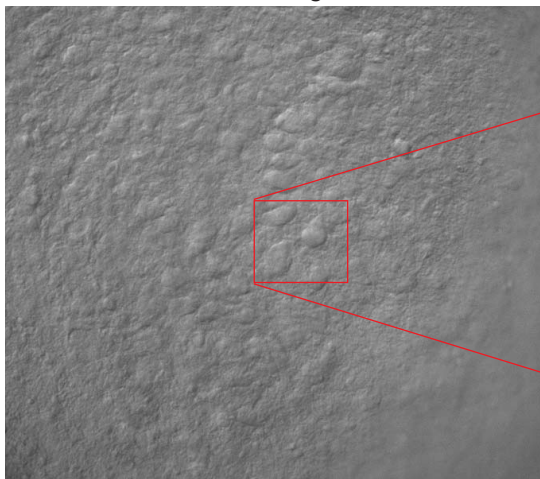

80× Intermediate magnification 4 x



Examples using  
intermediate  
magnification  
changer WI-DPMC

IR-DIC observation, trigeminal motoneuron, Tomio Inoue Ph.D, Department of Oral Physiology, Showa University

## 20X objective (XLUMPLFLN20XW) NA 1.0; W.D.: 2.0 mm

The 20X water immersion objective makes high-resolution observation possible with a wide range of intermediate magnification lenses. Since exchanges between low and high magnification are performed through the intermediate magnification changer, vibration is reduced to a minimum and the usual concern about collisions between objectives and patch clamp electrodes is eliminated.

## Simultaneous fluorescence and IR-DIC observations

With the included 690 nm dichroic mirror in the WI-DPMC, fluorescence light is sent to the front port, and IR-DIC light is sent to the back port allowing two cameras to image simultaneously with no vibration introduced by light path selection. IR-DIC observation is compatible with 775 nm and 900 nm wavelengths.

## Variable magnification dual port (WI-DPMC)

The WI-DPMC rear camera port includes a 2 position intermediate magnification selector. A high magnification 4X intermediate lens is included and a (0.25X or 0.35X) low magnification lens is optional. High or low magnification selection is via a single lever with no click-stops or detents allowing a specimen to be scanned and measured with minimal disturbance from vibration.

\*Available for 0.5X, 1X and 2X intermediate magnification lenses by special order.

## Variable click-stops

All click-stops, as when selecting between camera and observation modes, can be adjusted to the point of no click and thus no vibration.

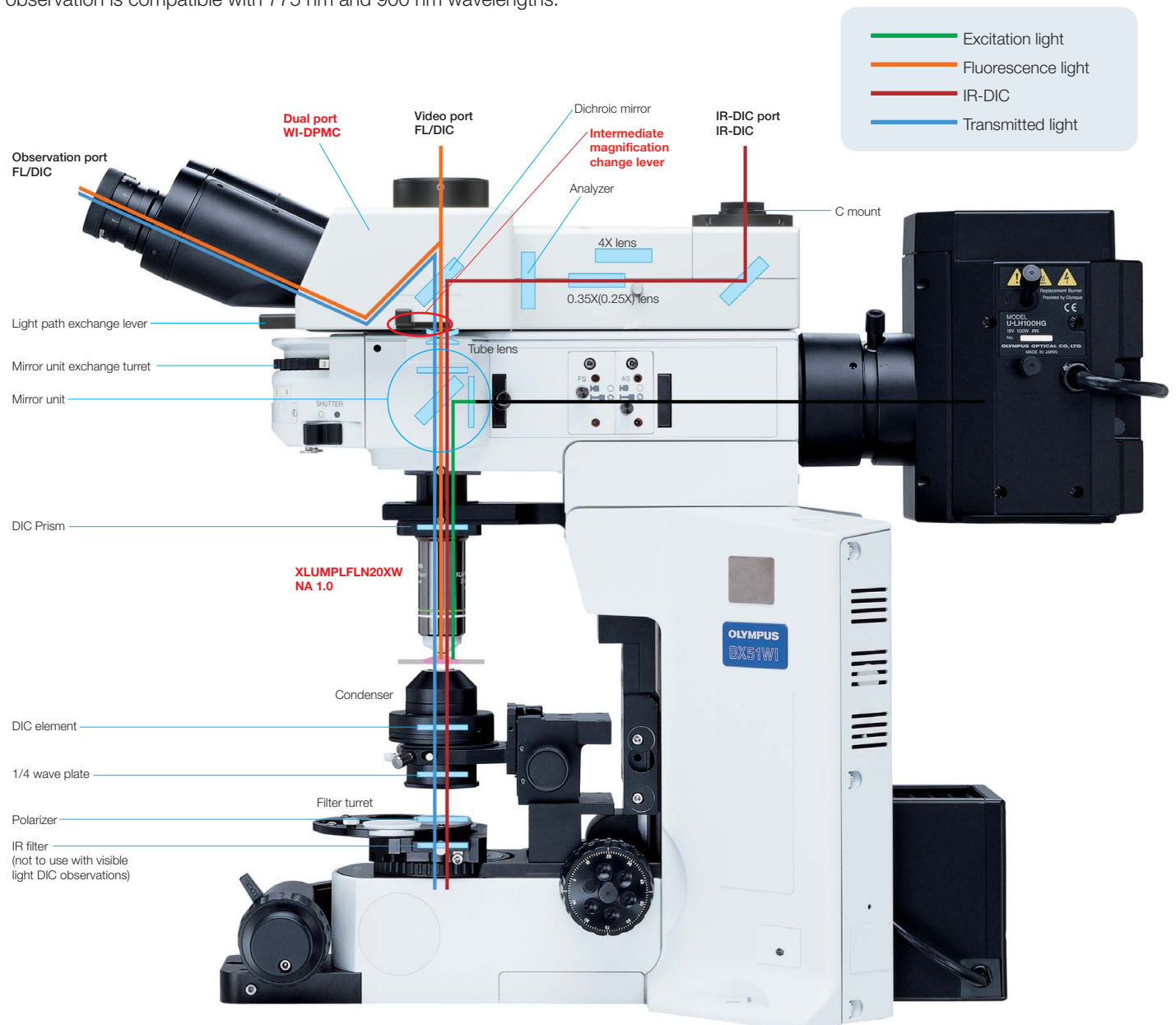

# Front operation with vibration-free and minimized noise

## Ideal concept in experimental operation

The front operation system prevents interference in patch clamping work. The design concept is simple and allows frequently performed operations like focusing or filter exchange to be done easily at the front of the unit.

Ample space is provided on both sides of the microscope frame and condenser, so the necessary manipulation equipment can be positioned close to the microscope.

### ❶ Vibration-free shutter

The fluorescence shutter slides horizontally with no detents and no vibration.



### ❷ Mirror unit turret with adjustable click release

The click-stop on the 6 position turret can be released with a precision screwdriver.



### ❸ Ample space around the condenser

Frame designed for ample space around the condenser, making it easy to adjust Nomarski DIC contrast, exchange filters, adjust the condenser's aperture stop and to easily switch between visible light, Nomarski DIC or IR-DIC.

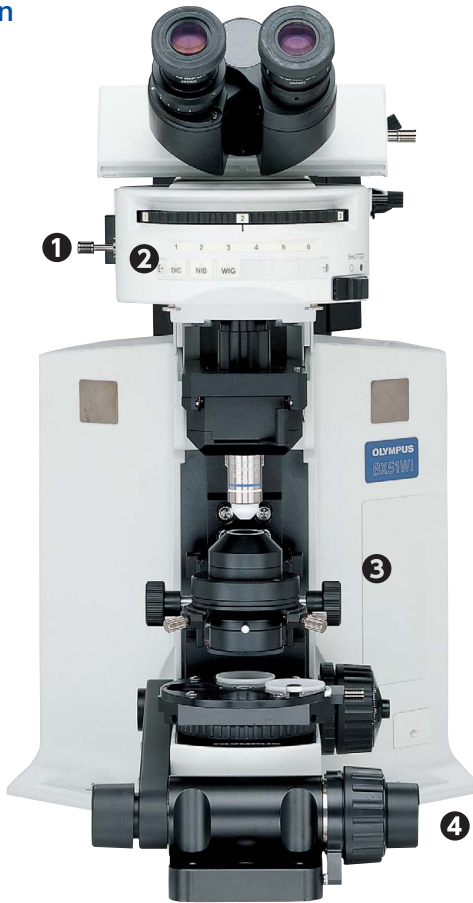

### ❹ Front focus knobs close to the operator's hand

Fine focus control is located at the front on both sides of the microscope body. The knob on the right integrates both coarse and fine focus control.

### ❺ Coarse focus lock lever

When engaged at the desired position, the objective can be raised with the coarse focus knob and then returned precisely to its original position.

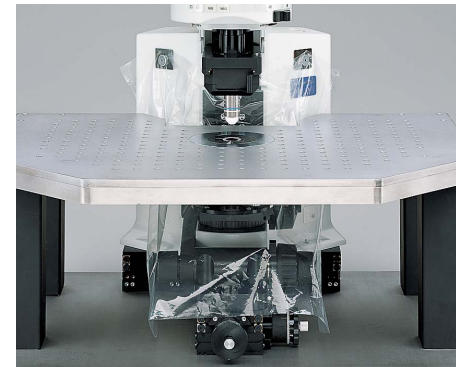

### ❻ A waterproofing sheet

A waterproofing sheet, attached by the supplied magnets, provides protection against liquid overflow and spills. The sheet is large enough to protect the frame, condenser and focusing mechanisms.



### 7 Remote power supply and hand switch

The remote TH4 power supply for transmitted light is designed with no cooling fan to minimize electrical noise. Features on/off and intensity controls. Can also be used with the optional TH4-HS hand switch providing light intensity and on/off control a maximal distance away from the Faraday cage.

## Olympus offers a wide choice of nosepieces for different applications



### Swing nosepiece WI-SRE3

Unique slim, compact design and front-to-back swing motion permits objective changes without interfering with electrodes and micromanipulators. Objective positioning incorporates a vibration-free counterspring mechanism.



### Slide nosepiece U-SLRE

This nosepiece is designed for the attachment of one large diameter, low magnification fluorescence objective (XLFLUOR 2X/340 or 4X/340) and one objective with normal (RMS) diameter threads. Nosepiece motion is a simple horizontal slide.



### Single position nosepiece WI-SNPXLU2

Designed to accept the unique, large diameter XLUMPLFLN20XW objective.



### RMS adapter WI-RMSAD

This adapter enables the attachment of an objective with RMS thread size to the WI-SNPXLU2.

## The swing-slide nosepiece prevents the intrusion of air bubbles

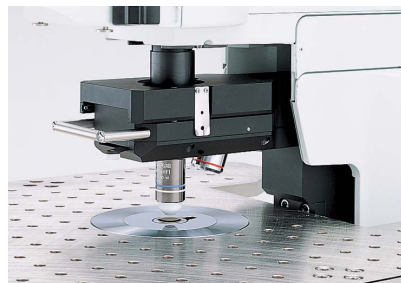

Swing-slide nosepiece WI-SSNP

This nosepiece features a swing-slide motion, whereby the objective swings forward while being raised. As a result, the objective clears the walls of the perfusion chamber. This motion also prevents the trapping of air bubbles when the objective is lowered.

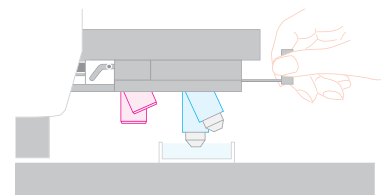

# Functionality and solutions to meet a wide variety of needs

## Experimenting with small animals

### Raising the objective and lowering the stage to enable small animal experiments

The arm height raising kit (WI-ARMAD) provides an additional 40 mm of clearance and is mounted between the microscope frame and the reflected light illuminator. Small animal experiments usually do not require transmitted light thus allowing the removal of the substage condenser assembly. After removal, the stage may be lowered an additional 50 mm, providing a total clearance increase of 90 mm.

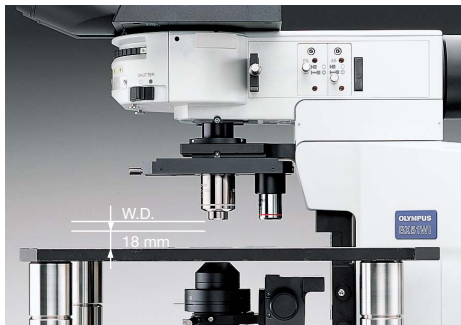
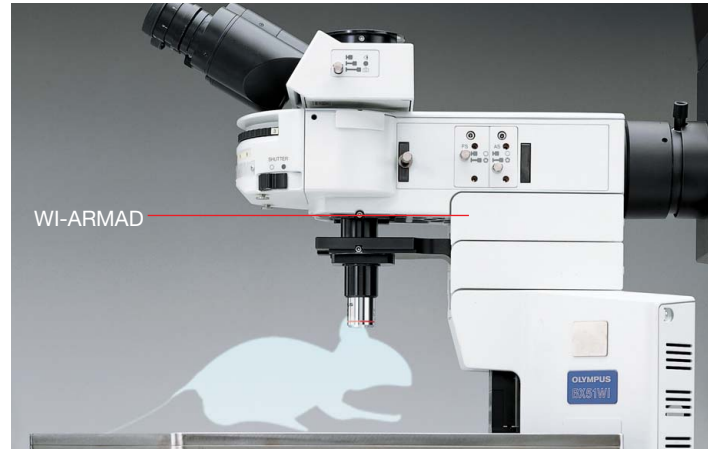

Normal configuration

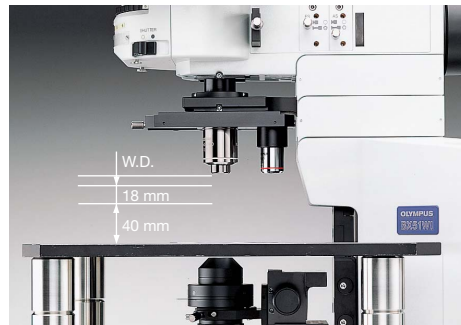

40 mm more clearance via WI-ARMAD



Detaching the condenser assembly and lowering the stage by 50 mm provides maximal clearance

## Photoactivation

### A variety of convenient units to add light sources and control the light

#### Lamphouse adapter U-LHAD

This adapter allows the mounting of the dual port (U-DP) between the microscope frame and lamp housing.

#### Rectangular field stop U-RFSS

Designed for use with CCD cameras, prevents photobleaching of the specimen outside of the imaging area.

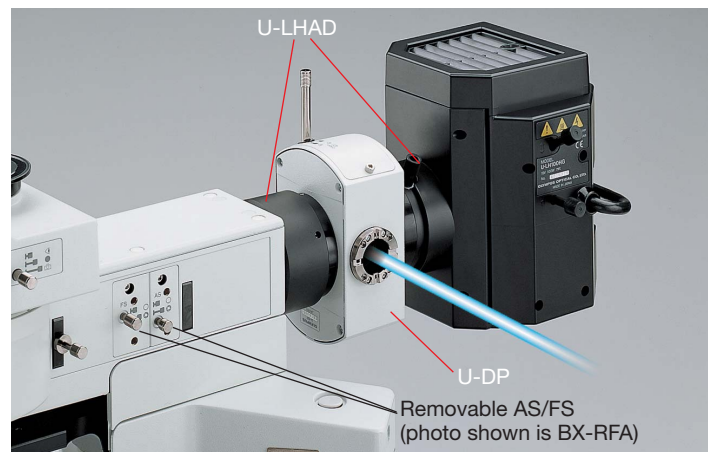

U-RFSS





BX51WI+WI-STAD+U-SVRB-4

## Microinjection

### BX Stage and adapter for injection experiments

The stage adapter WI-STAD is designed to allow the attachment of a traditional microscope right or left hand stage to the WI frame. The compact design of the BX2 stage (U-SVRB-4, or U-SVLB-4) reduces the distance between the specimen and the manipulator and creates a stable platform for injections.



BX51WI+IX-SVL2

## Culture cell observation

IX-SVL2 general purpose platform stage. Mounts for left or right hand operation. Provides stable specimen X-Y movement.

# Outstanding image clarity for electro-physiological experiments

## IR-DIC/ Nomarski DIC observation

### IR-DIC optimized optics:

#### Designed for observations at 775 nm to 900 nm

Thanks to the precisely aberration-compensated IR-DIC optics covering from visible to near infrared light of 775 nm/900 nm wavelength, the clarity of images observed under near infrared light has been improved still further, allowing clear observation of even deep sections of brain slice.

- **Visible light DIC**

Allows operator high-resolution observation of the tissue surface.

- **775 nm IR-DIC**

In combination with an IR camera allows observation within the tissue slice. Optics are corrected for visible and IR wavelengths allowing fast switching between wavelengths with minimal refocusing.

- **900 nm Nomarski DIC**

Allows observation deeper into the tissue (requires special polarizer and analyzer optimized for 900 nm).

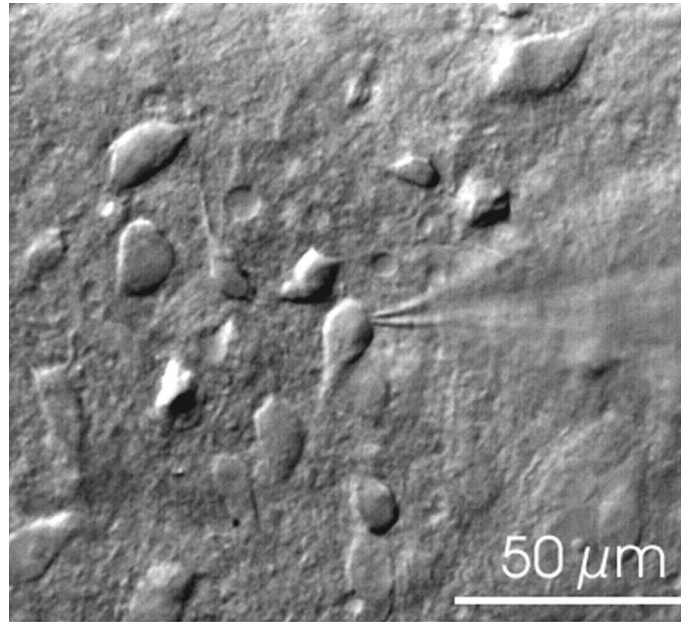

Nucleus of solitary tract from slice of rat medulla oblongata (thickness: 400 μm)  
Prof. Fusao Kato  
School of Medicine Physiology Dept.,  
Jikei University  
*Kato & Shigetomi, J. Physiol. (2001), 530: 469-486*

## Senarmont compensation for Nomarski DIC observation

When using a Senarmont equipped condenser, all contrast adjustments are performed with the 1/4 wave plate below the condenser, thus eliminating the risk of bumping the stage, specimen, manipulators or nosepiece.

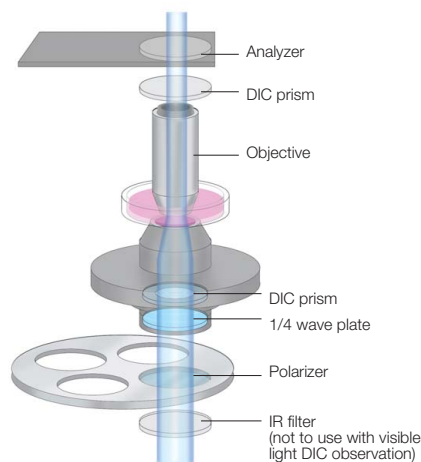

## Universal condenser with DIC for improved contrast

Suitable for use in visible and 775 nm/900 nm near-infrared light, the U-UCD8 universal condenser is a high NA, short working distance condenser offering improved contrast in nerve cell observations, for example.



## Oblique illumination observation

### Oblique observation optimizes contrast by changing the direction of the specimen shadow

Olympus has developed an oblique condenser (WI-OBCD) whose long working distance enables the angles of shadow to be altered through 360 degrees without moving the specimen. Requiring no additional accessories, oblique illumination is easy to set up and control. Plastic dishes (normally unsuitable for all types of DIC) are easy to image with oblique illumination. The oblique illumination slit aperture is variable in size and on a slider allowing quick changeover.

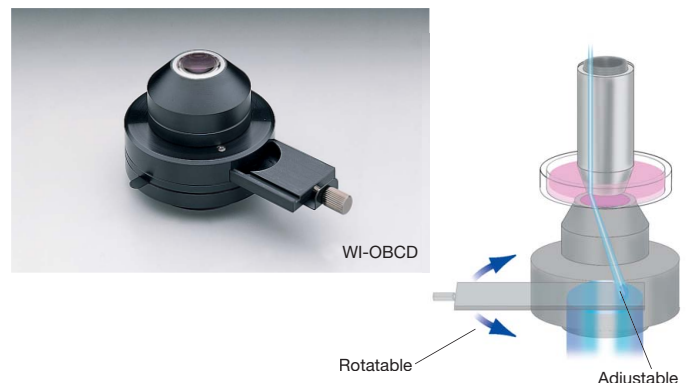

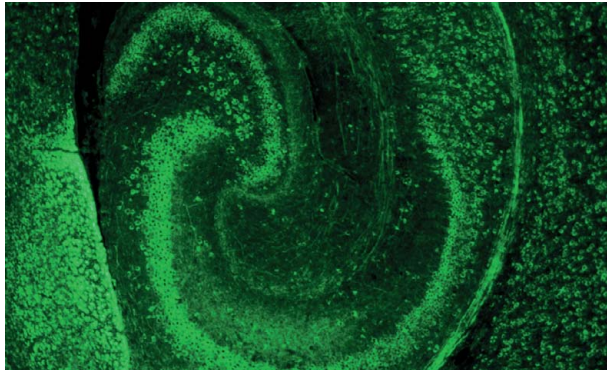

Transverse cryostat section through the hippocampus of a mouse at postnatal day 10 was stained with a mouse monoclonal anti-neurofilament-L (Chemicon, MAB1615) . An FITC-conjugated anti-mouse antibody was used for detection of NF-L. Objective: XLFLUOR4X/340

Masaharu Ogawa, Ph.D  
Laboratory for Cell Culture Development, Brain Science Institute, Riken

## Fluorescence macro observation

2X and 4X macro lenses with high numerical apertures provide fluorescence images  
Designed for GFP imaging of large cells such as neurons

2X and 4X low magnification fluorescence objectives and a special GFP observation mirror unit are available. The objectives have a long working distance for maximum flexibility. An optional water immersion cap (XL-CAP) is also available to remove image aberrations caused by ripples on water surface of immersed specimens.



## Observing changes in membrane potential

Measuring changes in membrane electric potential by using the XLUMPLFLN20XW objective with NA 1.0

The XLUMPLFLN20XW objective, with its high NA, and 2.0 mm of working distance allows the measurement of cell membrane electric potential (as seen right). Also, the 4X macro objective (XLFLUOR4X/340) can be used to measure membrane potential at the tissue level. A water immersion cap (XL-CAP) can be attached to the macro 2X or 4X objectives to eliminate disturbances caused by water ripples.

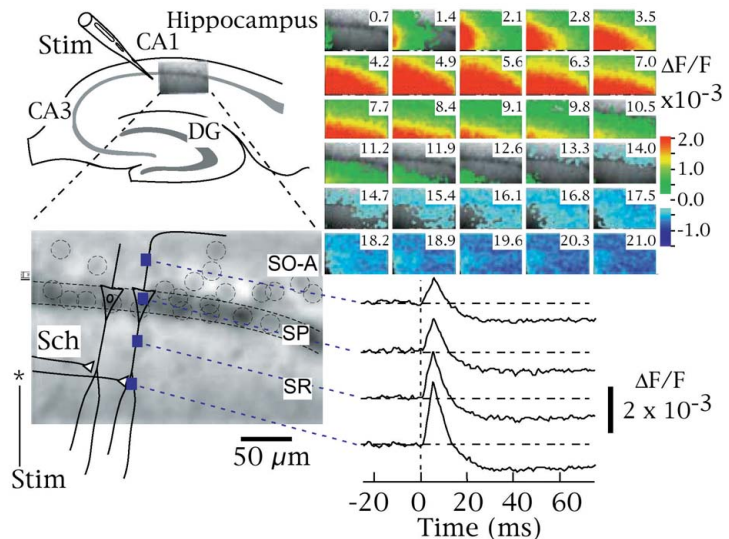

### Imaging of neuronal activity with voltage sensitive dye

Spread of neural activity in area CA1 of acute rat hippocampal slice (400 μm thick) in response to a single stimulation applied to Schaffer collateral pathway imaged (at frame rate of 0.7 ms/frame) with a fluorescent voltage sensitive dye (VSD; Di-4-ANEPPS). The fluorescent image (90 x 60 pixels) captured by a digital high-speed CCD camera (MiCAM01, Brain Vision Inc.; with 20X super high NA objective and 0.5X adapter) is superimposed on the illustration of a hippocampal slice (upper left panel). The image is enlarged and shown on the illustration of pyramidal cells (solid line) (lower left panel). Each lamina of CA1 is shown as follows: SO-A, Stratum oriens-alveus; SP, Stratum pyramidal; SR, Stratum radiatum. The individual somas of cells were visible (indicated by dotted circle on the image) and were found along the stratum pyramidal. The changes in the fluorescence of VSD (optical signal) in accordance with the membrane potential change upon a stimulation (Stim) onto Schaffer collateral (Sch) were pseudo-color encoded and shown as consecutive images (upper right panel; number in each image shows time from the stimulation (ms)). The depolarizing signal (red) spread along Schaffer collateral, which was followed by a hyperpolarizing signal (blue) originated in stratum pyramidal. The time courses of optical signals in representative pixels are shown in lower right traces.

Takashi Tominaga Ph.D, Brain-Operative Device Lab., Brainway Group, Brain Science Institute, Riken

\* The above data were obtained using a forerunner to the XLUMPLFLN20XW, but the XLUMPLFLN20XW can be used to perform the same operations.

# Accessories

## Multi double port tube U-DPTS

The U-DPTS accepts an optional dichroic mirror allowing the incoming to be split between visible and infrared and be observed simultaneously using two cameras.

\* A fluorescence mirror unit is required.

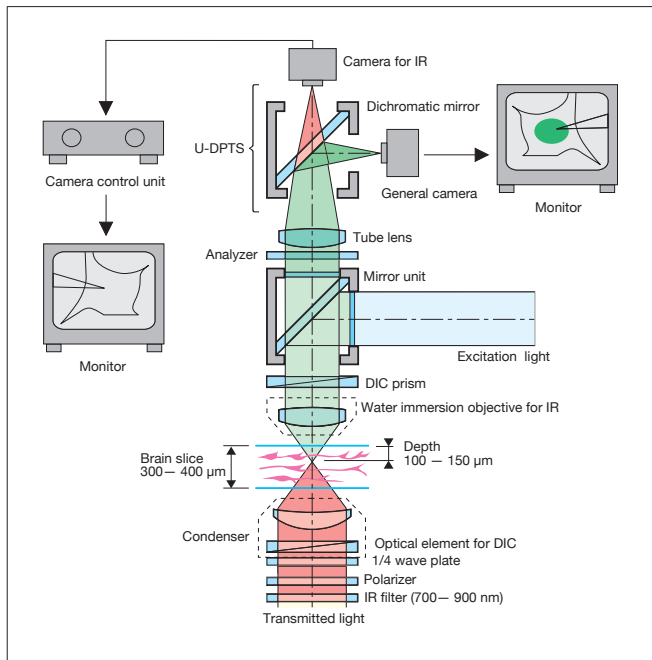

## Intermediate magnification changer U-ECA, U-CA

The U-ECA, which includes a 2X intermediate magnification position, allows quick magnification changes to a camera or observer without the need to change objectives. The U-CA includes a 4 position turret that allows rapid switching between a 1X, 1.25X, 1.6X and 2X positions. Both changers accept standard Olympus adapters for attaching a wide range of cameras.

\* U-ECA and U-CA are not recommended for IR observation with the U-TR30 trinocular observation head.



## C-mount video magnification change unit (IR-compliant) U-TVCAC

The U-TVCAC includes a 3-position turret with 1X, 2X, and 4X IR corrected positions. Includes a standard c-mount top port.



## Objectives



Objectives		NA	W.D. (mm)	Visible light	775 nm	900 nm
No Cover Objective	MPLN5X	0.10	20.0	○	—	—
Long Working Distance No Cover Water Immersion Objective	UMPLFLN10XW	0.30	3.5	○	○	○
	UMPLFLN20XW	0.50	3.5	○	○	○
	LUMPLFLN40XW	0.80	3.3	○	○	○
	LUMPLFLN60XW	1.00	2.0	○	○	○
	LUMFLN60XW	1.10	1.5	○	○	○
Long Magnification Fluorescence Objective	XLFLUOR2X/340	0.14	21.0 (include 5 mm water)	○	○	—
	XLFLUOR4X/340	0.28	29.5 (include 5 mm water)	○	○	—
20X Super High NA Objective	XLUMPLFLN20XW	1.00	2.0	○	○	○

## BX51WI/BX61WI Specifications

Optics		UIS2 optical system	
Material		Aluminum	
Illumination	BX51WI	Microscope body	Built-in Koehler illumination for transmitted light (FN 22), external light source, 12 V 100 W long life halogen bulb (pre-centered)(average lifetime: approximately 2,000 hours)
		Light source TH4	Light adjustment: DC2.5 V ~ 12.6 V (continuous adjustment) 8.4 A max. Power consumption: 150 W, dimensions: 75 (W) x 125 (H) x 200 (D) mm, weight 2 kg
	BX61WI	Microscope body	Built-in Koehler illumination for transmitted light (FN 22) 12 V 100 W long life halogen bulb (pre-centered) (average lifetime: approximately 2,000 hours) Light adjustment: less than DC2 V ~ 12 V (continuous adjustment) Brightness adjustment, light preset switch
		Light source BX-UCB	Power consumption: 200 W, dimensions: 125 (W) x 216 (H) x 310 (D) mm, weight 5 kg
Focus	BX51WI	Nosepiece focus by roller guide (rack & pinion) Stroke per rotation; fine: 0.1 mm coarse: 15 mm maximum stroke: 25 mm Coarse lower limit stopper mechanism, Torque adjustment mechanism for coarse focus	
	BX61WI	Motorized focusing using stepping motor and ball screw Nosepiece focus by cross roller guide Minimum graduation; fine: 1 μm (sensitivity 1 μm) resolution: 0.01 μm, maximum stage movement speed: 3 mm/s. Stroke per rotation; fine: 0.1 mm coarse: 1 mm Stroke: 25 mm, stage escape mechanism	
Nosepiece	WI-SRE3	Swing nosepiece	DIC prism: WI-DICTHRA, WI-DICT nosepiece arm: WI-NPA
	U-SLRE	Slide nosepiece	DIC prism: DIC observation is not available nosepiece arm: WI-NPA
	WI-SNPXLU2	Single position nosepiece	DIC prism: WI-DICTHRA, WI-DICT nosepiece arm: WI-NPA
	WI-SSNP	Swing-slide nosepiece	DIC prism: WI-DICTHRA, WI-DICT nosepiece arm: integrated
Fluorescent Illuminator	BX-RFA	BX fluorescence illuminator, excitation balancer attachable, FS/AS detachable	
	BX-URA2	BX reflected light illuminator	
Observation Tube	U-TR30-2	Trinocular, FN: 22, inclination angle: 30°, interpupillary distance: 50 mm — 76 mm Light path exchange; 3 steps ① BI: 100% ② BI: 20% video, photo: 80% ③ Video, photo: 100%	
	U-ETR-4	Erect image trinocular, FN: 22, inclination angle: 30°, interpupillary distance: 50 mm — 76 mm Light path exchange; 2 steps ① Binocular: 100% ② Video, photo: 100%	
	WI-DPMC	Double port magnification change unit, FN: 22, inclination angle: 24°, interpupillary distance: 50 mm — 76 mm, Light path exchange; 3 steps	
Stage	IX-SVL2	Mechanical stage, fixed to microscope body with WI-FSH, cross movement mechanism, X, Y axes handle torque adjustable (rack & pinion), movement range: 43 mm (Y) x 50 mm (X)	
	U-SVL(R)B-4	Used together with WI-STAD, cross movement mechanism, X, Y axes handle torque adjustable (rack & pinion), movement range: 52 mm (Y) x 76 mm (X)	
Long Working Distance Condenser	WI-UCD	Universal condenser, NA: 0.8, W.D.: 5.7 mm, with variable A.S. mechanism, turret: 4-position, four DIC prisms attachable Built-in quarter wavelength plate	
	WI-DICD	DIC condenser, one DIC prism attachable	
	WI-OB CD	Oblique condenser, built-in variable oblique illumination stop	

## WI-DPMC Specifications

Optical light path exchange	3 steps	BI: 100% Front port 100% Simultaneous use of front (visible light) and back (near IR light) ports		
		Clicker ability adjustable		
Binocular observation tube		FN 22, inclination angle 24°, Interpupillary distance: 50 — 76 mm		
Front port		For fluorescent observation, FN 22, Simultaneous adjustment function with backport		
Back port		For IR observation (c mount adapter)		
Magnification change (when combining with XLUMPLFLN20XW)		Magnification changer lens magnification	Total magnification	NA
		0.25x	5x	0.15
		0.35x	7x	0.22
		0.5x*	10x	0.4
		1x*	20x	0.95
		2x*	40x	0.95
		4x	80x	0.95
IR-DIC observation		Insert 775 nm analyzer or 900 nm analyzer into WI-DPMC		

\* Custom made product

# BX2WI System Diagram

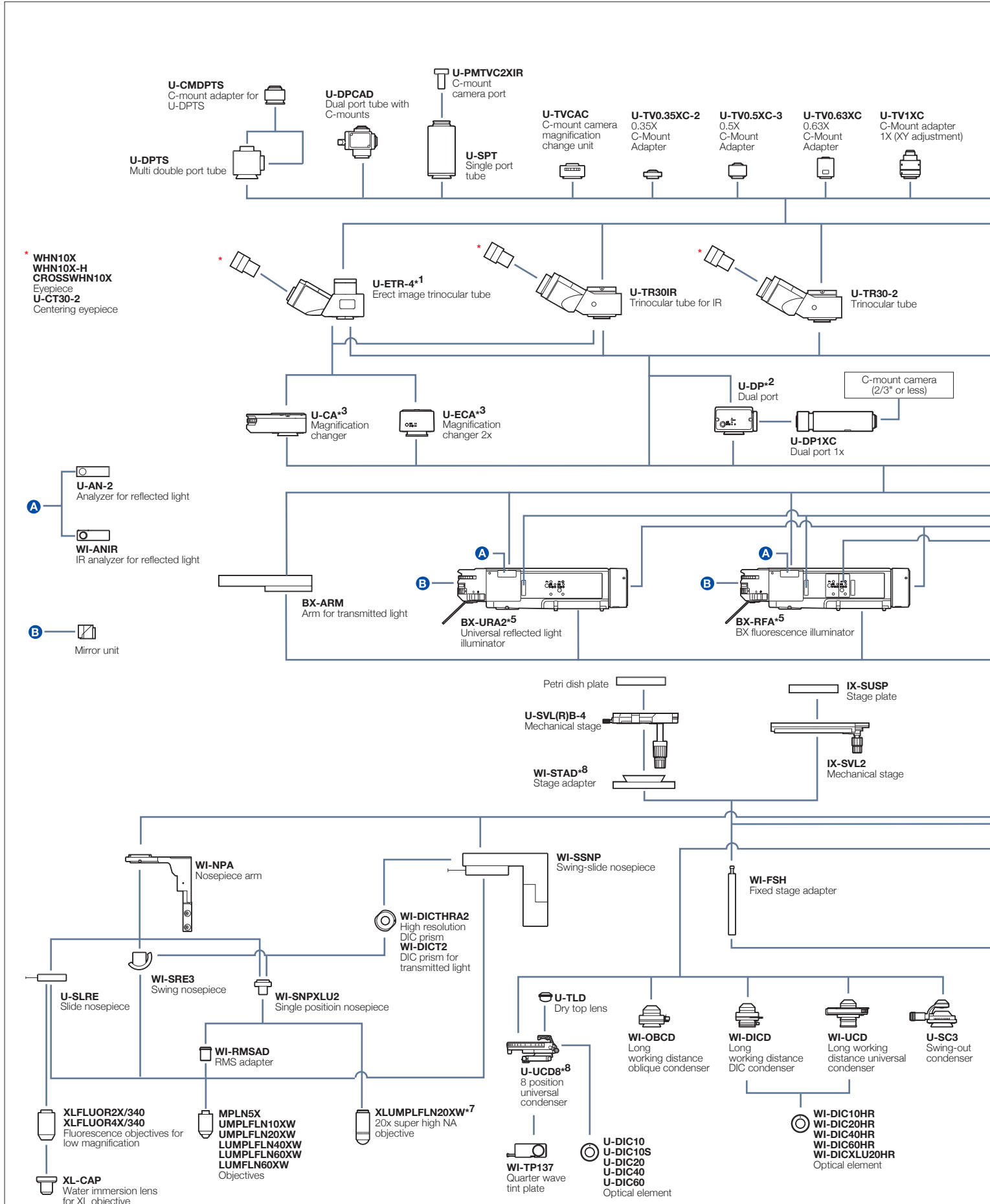

<sup>\*1</sup> Slight vignetting may occur in the periphery of the field of view in combination with an additional intermediate attachment. <sup>\*2</sup> Slight vignetting may occur in the periphery of the field of view in combination with fluorescence illuminator. <sup>\*3</sup> Can be used with U-ETR-4 and U-TR30IR. Field of view is limited when using more than two intermediate tubes. <sup>\*4</sup> Sub port can accept U-TV1X-2, and 2/3" or less CCD cameras.

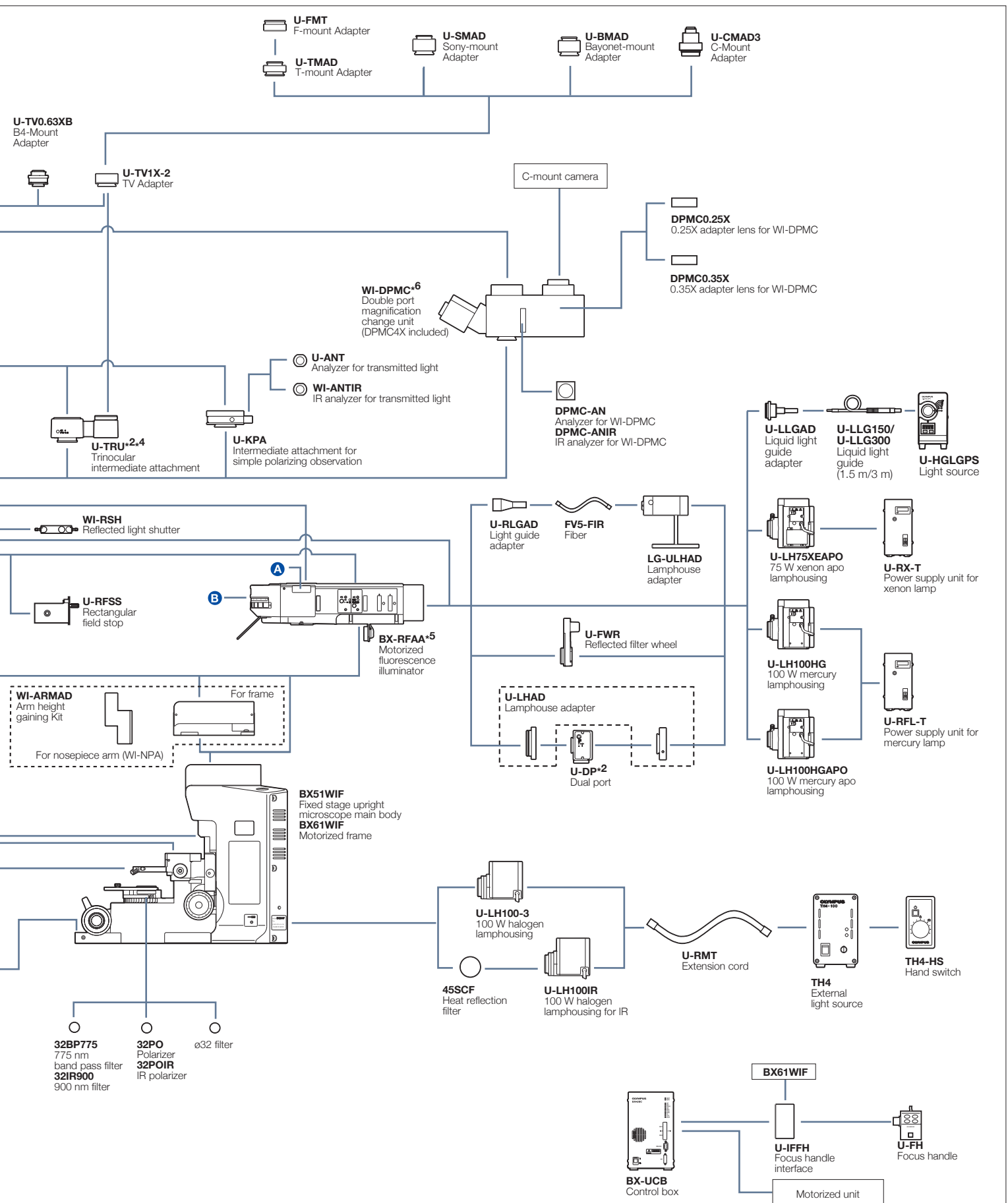

<sup>5</sup> FN is 22 when fluorescence observation. <sup>6</sup> Use with fluorescent illuminator. <sup>7</sup> Acceptable camera adapters are U-TV1X-2, U-TVACA and U-PMTC2XIR. <sup>8</sup> U-UCD8 cannot be used with WI-STAD.

## BX51WI Dimensions

(unit: mm)

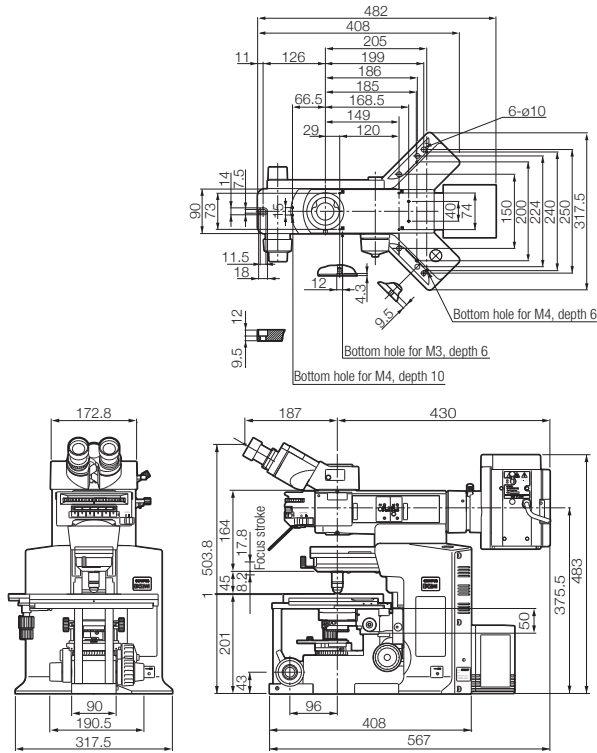

## BX61WI Dimensions

(unit: mm)

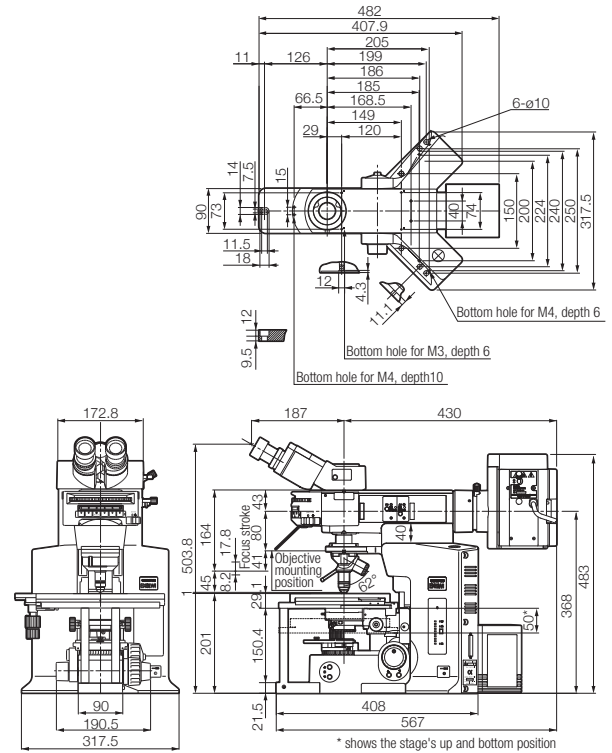

## BX51+WI-DPMC Dimensions

(unit: mm)

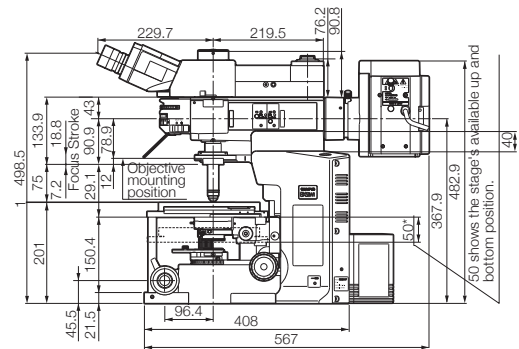

[www.olympus-lifescience.com](http://www.olympus-lifescience.com)

**OLYMPUS**

For enquiries - contact

[www.olympus-lifescience.com/contact-us](http://www.olympus-lifescience.com/contact-us)

**OLYMPUS CORPORATION**  
Shinjuku Monolith, 2-3-1 Nishi-Shinjuku, Shinjuku-ku, Tokyo 163-0914, Japan  
**OLYMPUS EUROPA SE & CO. KG**  
Wendenstrasse 14-18, 20097 Hamburg, Germany  
**OLYMPUS CORPORATION OF THE AMERICAS**  
3500 Corporate Parkway, P.O. Box 610, Center Valley, PA 18034-0610, U.S.A.  
**OLYMPUS SINGAPORE PTE LTD.**  
491B River Valley Road, #12-01/04 Valley Point Office Tower, Singapore 248373  
**OLYMPUS MEDICAL SYSTEMS INDIA PRIVATE LIMITED,**  
Ground Floor, Tower-C, SAS Tower, The Medicity Complex, Sector-38, Gurgaon 122001, Haryana, India

**OLYMPUS LATIN AMERICA, INC.**  
5301 Blue Lagoon Drive, Suite 290 Miami, FL 33126, U.S.A.  
**OLYMPUS (CHINA) CO., LTD.**  
A8F, Ping An International Financial Center, No. 1-3, Xinyuan South Road, Chaoyang District, Beijing, 100027 P.R.C.  
**OLYMPUS KOREA CO., LTD.**  
8F Olympus Tower, 446 Bongseunsa-ro, Gangnam-gu, Seoul, 06153 Korea  
**OLYMPUS AUSTRALIA PTY. LTD.**  
3 Acacia Place, Notting Hill VIC 3168, Australia

- OLYMPUS CORPORATION is ISO14001 certified.
- OLYMPUS CORPORATION is ISO9001 certified.
- OLYMPUS CORPORATION is ISO13485 certified.
- Illumination devices for microscope have suggested lifetimes. Periodic inspections are required. Please visit our website for details.

- All company and product names are registered trademarks and/or trademarks of their respective owners.
- Specifications and appearances are subject to change without any notice or obligation on the part of the manufacturer.